



## DEPARTMENT OF THE ARMY

THE INSTITUTE OF HERALDRY  
9325 GUNSTON ROAD, ROOM S113  
FORT BELVOIR, VIRGINIA 22060-5579

SAAA-IHS

05 March 2020

MEMORANDUM FOR Headquarters, United States Army Special Operations Command

SUBJECT: Beret Flash and Background Trimming for the 2nd Special Warfare Education Training Group (Airborne)

1. As a result of the redesignation and reorganization of the Special Warfare Education Group to the 2nd Special Warfare Training Group (Airborne), the following heraldic items are authorized effective 1 October 2019:

a. Beret Flash and Background Trimming. The descriptions of the designs are as follows:

### **BERET FLASH**

A shield-shaped embroidered item with a semicircular base 2 1/4 inches (5.72 cm) in height by 1 7/8 inches (4.76 cm) in width overall, edged with a 1/8 inch (.32 cm) yellow outer border, silver and black divided diagonally from upper left to lower right by a blue bar over white bar.

### **BACKGROUND TRIMMING**

An oval shaped embroidered item 1 3/8 inches (3.49 cm) in height by 2 1/4 inches (5.72 cm) in width overall, edged with a 1/8 inch (.32 cm) yellow outer border, silver and black divided diagonally from upper left to lower by a blue bar over white bar.

b. This authorization does not grant exclusive use of the above colors and pattern design for the 2nd Special Warfare Training Group (Airborne).

2. Enclosed for use in procurement of the items are:

a. Manufacturing drawings (TIOH Drawing No. A-4-327 and A-6-346).

b. Digital artwork in color and black and white line.

c. A list of certified manufactures and procedures for local procurement of insignia.

3. This authorization cancels the beret flash and background trimming approved for the Special Warfare Education Group (TIOH Drawing A-4-287 and A-6-312) via TIOH Memo dated 18 November 2013.

SAAA-IHS

SUBJECT: Beret Flash and Background Trimming for the 2nd Special Warfare Education Training Group (Airborne)

4. This authorization is IAW AR 670-1 and Headquarters, United States Army Special Operations Command Permanent Orders 316-03, dated 12 November 2019. A copy of this memorandum will become part of your permanent organizational history files.

5. Your point of contact for this action is the Heraldic Services and Support Division at (571) 515-0321.

Encls

CHARLES V. MUGNO  
Director



**DEPARTMENT OF THE ARMY**  
HEADQUARTERS, UNITED STATES ARMY  
SPECIAL OPERATIONS COMMAND  
2929 DESERT STORM DRIVE  
FORT BRAGG, NORTH CAROLINA 28310-9110

PERMANENT ORDER 316-03

12 November 2019

Special Warfare Education Group, United States Army John F. Kennedy Special Warfare Center and School (USAJFKSWCS) (W1EOT3), Fort Bragg, North Carolina 28310-9110

The following organization or unit action is directed.

Action: Re-designated and reorganized as 2nd Special Warfare Training Group (Airborne) SP (W1EOT3), Fort Bragg, North Carolina 28310-9110.

Assigned to: United States Army John F. Kennedy Special Warfare Center and School (USAJFKSWCS) (W1E0AA), Fort Bragg, North Carolina 28310-9110

Mission: As stated in Section 1, TOA SPW1E0AA

Effective Date: 1 October 2019

Military Structure Strength: 36 OFF, 13 WO, 251 ENL, 300 Aggregate

Military Authorized Strength: 32 OFF, 13 WO; 251 ENL, 296 Aggregate

Civilian Structure Strength: 144

Civilian Authorized Strength: 131

Accounting Classification: Appropriate allotments will be obligated to extent necessary (AR 37-100 series).

Authority: AR 220-5

Additional Instructions:

a. The Commanding General, USAJFKSWCS (W1E0AA), exercises General Court Martial Convening Authority (GCMCA) for general administration of military justice and administrative actions over assigned personnel.

b. The Commander, 2nd Special Warfare Training Group (Airborne), USAJFKSWCS, will exercise Special Court-Martial Convening Authority (SPCMCA) for general administration of military justice and administrative actions over assigned personnel.

c. The Commanders, 2nd and 6th Battalions, 2nd Special Warfare Training Group (Airborne), USAJFKSWCS, will exercise Summary Court-Martial Convening Authority (SCMCA) for general administration of military justice and administrative actions over all personnel assigned.

d. Subordinate Commanders will exercise the general administration of military justice, delegated administrative actions, in accordance with AR 27-10 and USASOC Supplement to AR 27-10.

e. The official authorization document for unit to cite as authority for requisitioning personnel and equipment is TOA SPW1E0AA, CCNUM0120, EDATE 01 October 2019.

f. Designated Derivative Unit Identification Codes are:

- (1) HHC 2 BN 2ND SPWAR T GRP (W1E0HX)
- (2) B CO 2 BN 2ND SPWAR T GRP (W1E0BX)
- (3) C CO 2 BN 2ND SPWAR T GRP (W1E0C0)
- (4) D CO2 BN 2ND SPWAR T GRP (W1E0DX)
- (5) HHD 6 BN 2ND SPWAR T GRP (W1E0HU)
- (6) A CO 6 BN 2ND SPWAR T GRP (W1E0AC)
- (7) A CO 6 BN 2ND SPWAR T GRP DET W (W1E0AZ)
- (8) B CO 6 BN 2ND SPWAR T GRP (W1E0BC)
- (9) C CO 6 BN 2ND SPWAR T GRP (W1E0CC)

Format: 740

FOR THE COMMANDER:

JEFFERSON.FRANK.E  
ARLJR.1022456802

Digitally signed by  
JEFFERSON.FRANK.EARLJR.1022  
456802  
Date: 2019.11.15 11:36:50 -05'00'

FRANK JEFFERSON  
Lieutenant Colonel, GS  
Deputy Chief of Staff, G-1

DISTRIBUTION:

File (1)

Commander, U.S. Army Special Operations Command, (AOFD-FM, AOPE, AOOB, AOLO, AORA, AOEN, AOHS), Ft Bragg, NC 28310-9110 (1)

Commander, USAJFKSWCS (AOJK-FD), Ft. Bragg, NC 28310 (1)

Commander, 528th Sustainment Brigade (SO) (A), Ft Bragg, NC 28310 (1) Director, U.S. Army Force Management Support Agency, (MOFI-FMA) 9900 Belvoir Road, Ft Belvoir, VA 22060 (1)

HODA, G-1 (DAPE), 400 Army Pentagon, Washington, DC 20310-0400 (1)

HODA, G-3 (DAMO-FDF, DAMO-ZA, DAMO-ODZ) 400 Army Pentagon, Washington, DC 20310-0400 (1)

Commander, U.S. Army Center of Military History (DAMH-FPO), 102 4th Ave, Bldg. 34, Fort McNair, Washington, DC 20319 (1)



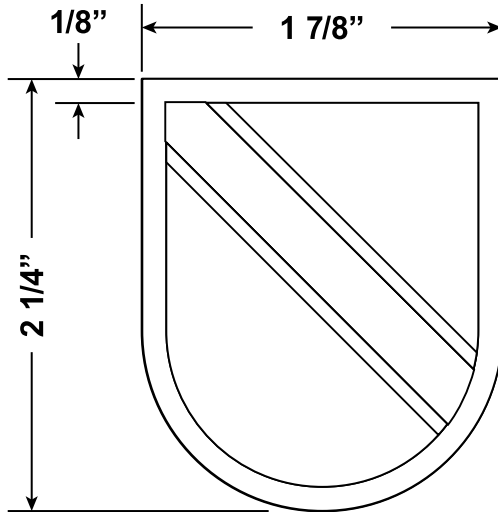

The Institute of Heraldry 9325 Gunston Road, Room S-112, Fort Belvoir, VA 22060- 5579 (1)

**REVISIONS**



**DESIGNED FOR  
OVEREDGE STITCHING**



-  **Silver Gray Cable No. 67137**
-  **White Cable No. 67101**
-  **Yellow No. 67108**
-  **Ultramarine Blue Cable No. 67118**
-  **Black Cable No. 67138**



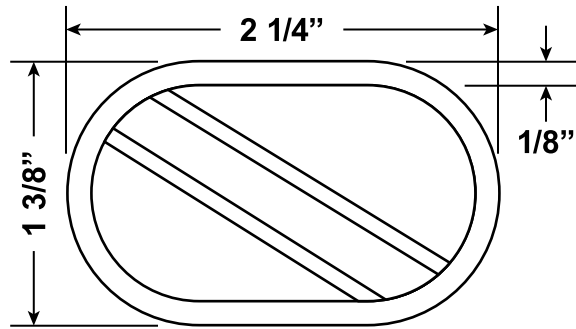

<b>PREPARED</b>	<b>SNP</b>	<b>THE INSTITUTE OF HERALDRY, DEPARTMENT OF THE ARMY</b> 9325 GUNSTON RD, RM S-113 FORT BELVOIR, VA 22060-5579					
<b>EXAMINED</b>	<i>SAO</i>						
<b>HDD CHIEF</b>	<b>AWW</b>	<b>BERET FLASH FOR 2ND SPECIAL WARFARE TRAINING GROUP</b>					
<b>APPROVED</b>							
<hr/> <p align="center"><i>CHARLES V. MUGNO, DIRECTOR</i></p>		<table border="1"> <tr> <td>SCALE</td> <td><b>DISTRIBUTION A.</b></td> <td rowspan="2" style="font-size: 2em;"><b>A-4-327</b></td> </tr> <tr> <td><b>FULL</b></td> <td>APPROVED FOR PUBLIC RELEASE</td> </tr> </table>	SCALE	<b>DISTRIBUTION A.</b>	<b>A-4-327</b>	<b>FULL</b>	APPROVED FOR PUBLIC RELEASE
SCALE	<b>DISTRIBUTION A.</b>	<b>A-4-327</b>					
<b>FULL</b>	APPROVED FOR PUBLIC RELEASE						
<b>MATERIALS: TO BE MANUFACTURED IN ACCORDANCE WITH MIL-DTL-14652</b>							
		<b>DATE: 05 MARCH 2020</b>					

**REVISIONS**



**DESIGNED FOR  
OVEREDGE STITCHING**

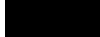

-  *Silver Gray Cable No. 67137*
-  *White Cable No. 67101*
-  *Yellow No. 67108*
-  *Ultramarine Blue Cable No. 67118*
-  *Black Cable No. 67138*

<b>PREPARED</b>	<b>SNP</b>	<b>THE INSTITUTE OF HERALDRY, DEPARTMENT OF THE ARMY</b> 9325 GUNSTON RD, RM S-113 FORT BELVOIR, VA 22060-5579
<b>EXAMINED</b>	<i>SAO</i>	
<b>HDD CHIEF</b>	<b>AWW</b>	<b>BACKGROUND TRIMMING</b> <b>2ND SPECIAL WARFARE</b> <b>TRAINING GROUP</b>
<b>APPROVED</b>		
<hr/> CHARLES V. MUGNO, DIRECTOR		SCALE <b>FULL</b>
		<b>DISTRIBUTION A.</b> APPROVED FOR PUBLIC RELEASE
		<b>A-6-346</b>

**MATERIALS: TO BE MANUFACTURED IN ACCORDANCE WITH MIL-DTL-14652**      **DATE: 05 MARCH 2020**



## 2<sup>ND</sup> SPECIAL WARFARE TRAINING GROUP



### BERET FLASH

**Description.** A shield-shaped embroidered item with a semicircular base 2 1/4 inches (5.72 cm) in height by 1 7/8 inches (4.76 cm) in width overall, edged with a 1/8 inch (.32 cm) yellow outer border, silver and black divided diagonally from upper left to lower right by a blue bar over white bar.



### BACKGROUND TRIMMING

**Description.** An oval shaped embroidered item 1 3/8 inches (3.49 cm) in height by 2 1/4 inches (5.72 cm) in width overall, edged with a 1/8 inch (.32 cm) yellow outer border, silver and black divided diagonally from upper left to lower by a blue bar over white bar.

**Background.** The beret flash and background trimming were approved effective 1 October 2019.



<https://tioh.army.mil>  
[usarmy.belvoir.hqda.mbx.tioh-webmaster@mail.mil](mailto:usarmy.belvoir.hqda.mbx.tioh-webmaster@mail.mil)  
8 August 2019

## LOCAL PROCUREMENT PROCEDURES OF INSIGNIA

--

1. Authorization for local procurement of insignia as specified in paragraph 3 below is contained in AR 710-2 and AR 670-1. Distinctive Unit Insignia (DUI) and regimental collar insignia (RCI) are locally procured. In addition, authorized shoulder sleeve insignia (SSI) may be locally procured until it is centrally procured and stocked through the Soldier Systems Directorate, Philadelphia. After shoulder sleeve insignia has been stocked by Philadelphia, local purchase is unauthorized.

2. After an insignia item has been approved by The Institute of Heraldry (TIOH), one of the following actions will be taken based upon the type of funds used for procurement:

a. Use of Appropriated Funds. Requisitions will be submitted through supply channels and purchased by local command servicing procurement officers for Active Army and Army Reserve units and by the USP&FO for Army National Guard units. A purchase request for local procurement will be prepared and submitted to the contracting officer in accordance with local procedures. The contracting officer will provide the manufacturer with the official manufacturing drawing for bidding purposes. Upon obtaining an acceptable bid, the contracting officer will advise the selected manufacturer to contact TIOH for loan of government tools to be used in manufacturing metal insignia items. A drawing is not required for RCI.

b. Use of Nonappropriated Funds. AR 670-1 permits use of nonappropriated funds (Unit Fund) for purchase of DUI when appropriated funds are not available. Unit funds may not be used to purchase SSI or RCI. A manufacturer must be selected from the list of manufacturers certified by TIOH for unit fund and other types of nonappropriated purchases, such as group purchases.

3. All insignia must be manufactured by firms certified by TIOH in accordance with AR 672-8. Procurement of insignia from non-certified manufacturers or from foreign or offshore sources is not authorized. Manufacturers who are interested in becoming certified manufacturers will be referred to the Director, The Institute of Heraldry for certification. All invitations for bids or contracts should include a statement that the insignia will be made in accordance with the specifications and tools provided by TIOH.

a. Distinctive Unit and Regimental Collar Insignia. DUI and regimental collar insignia must have the hallmark of the manufacturer stamped on the reverse. In addition, all DUI must have "Made in USA" stamped on the reverse. DUI will be manufactured in accordance with MIL-I-14654(IH). Regimental collar insignia will be



## LOCAL PROCUREMENT PROCEDURES OF INSIGNIA

--

manufactured in accordance with MIL-I-3575 for officers and MIL-I-15665 for enlisted personnel. Purchase request for DUI should include unit designation and the motto contained on the DUI, if applicable. Requests for regimental collar insignia or DUI should include unit designation and the motto contained on the DUI, if applicable. Requests for regimental collar insignia should include the name of the branch and the regimental number. Note: The battalion numerical designation will not be placed on Infantry, Armor, Cavalry, Field Artillery, Air Defense Artillery or Aviation regimental collar insignia. Hubs and/or dies will be loaned to the contractor by TIOH.

b. Shoulder Sleeve Insignia. Shoulder sleeve insignia will be manufactured in accordance with MIL-I-14652. The contractor will be advised that a "cartoon" (pattern) showing the placement and the number of stitches for the SSI may be obtained from TIOH.

c. ROTC Shoulder Loop Insignia. Solicitations for ROTC shoulder loop insignia should indicate that the insignia will be manufactured in accordance with MIL-I-14654(IH) and the contractor will be responsible for making any hubs and dies necessary for manufacturing. The design will be in accordance with the TIOH approved drawing.

d. Beret Flashes, Background Trimmings and ROTC Institutional SSI. The solicitation should indicate the insignia will be manufactured in accordance with MIL-I-14652 from the approved TIOH drawing. A "cartoon" (pattern) is not provided for these items.

4. The manufacturer is required to submit preproduction samples of all insignia to TIOH regardless of whether appropriated or nonappropriated funds are used for procurement. Once samples are approved, TIOH will issue a letter to the manufacturer authorizing manufacture of the insignia item. National Guard regulations currently require that a copy of the letter be forwarded by the manufacturer to the USP&FO prior to completion of the order. This procedure is recommended for inclusion in contracts by Regular Army and US Army Reserve procurement officers to insure that samples have been approved by TIOH.



<https://tioh.army.mil>  
[usarmy.belvoir.hqda.mbx.tioh-webmaster@mail.mil](mailto:usarmy.belvoir.hqda.mbx.tioh-webmaster@mail.mil)  
 15 April 2019

### TIOH CERTIFIED MANUFACTURERES

NAME	STREET	LOCATION	HMK	TYPE	PHONE	FAX
A B EMBLEMS/CONRAD	291 MERRIMON AVENUE	WEAVERVILLE, NC 28787	A35	1	828-645-3015	828-658-3581
ACTION EMBROIDERY CORP	1315 WEST BROOKS ST	ONTARIO, CA 91762	A25	1	800-638-7223	909-983-2755
BALLY RIBBON MILLS	23 NORTH SEVENTH ST	BALLY, PA 19503	B22	1d	610-845-2211	610-845-8013
BENDE & SONS, INC	180 AUTUMN ST	PASSAIC, NJ 07055	B26	1d	973-777-8700	973-777-7715
GREAT AMERICAN WEAVING	20 NORTH FRONT STREET	BALLY, PA 19503	G31	1d	610-845-9200	610-845-7147
HALLMARK EMBLEMS INC	2401 TAMPA STREET	TAMPA, FL 33602	H27	1	800-237-2567	813-273-0564
RELIABLE WORLD TRADE CO.	9849 KITTY LANE	OAKLAND, CA 94603	R-30	1c	510-614-2277	510-614-2277
SAYRE ENTERPRISES	324 EAST 32ND STREET	BUENA VISTA, VA 24416	S44	1	540-291-3800	EXT 217
WILLOW HILL SUPPLY, LLC	4707 ROCKWELL ROAD	WINCHESTER, KY 40391	W33	1	859-355-5244	859-355-5244
IRA GREEN (TEXTILES)	117 GEORGIA AVE	PROVIDENCE, RI 02905	G23	1	401-467-4770	

### CODES USED TO INDICATE TYPE OF MANUFACTURER

1 TEXTILE ALL

1a - SSI

1b - Badges

1c - Grade

1d - Ribbon

1e - Tapes